



LED Trail
Email: info@ledtrail.com
www.ledtrail.com

P/N: LTR-HB-150-1



DIMENSIONS

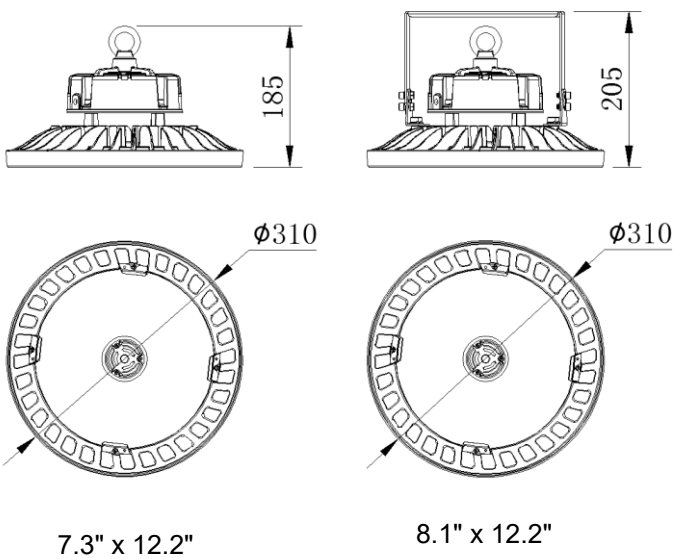

ADVANTAGE

- UL cUL certificate.
- IP65 driver, input voltage 100-277VAC.
- No UV or IR in the beam.
- Easy to install and operate.
- Energy saving, long lifespan.
- Light is soft and uniform, safe to eyes.
- Instant start.
- Green and eco-friendly without mercury.

APPLICATION

- Warehouse, factory and workshops;
- Highway toll station and gas station;
- Exhibition hall;
- Gymnasium and supermarkets, etc.

SPECIFICATIONS

OPTICAL	Input Power	150W
	Cover	Flat clear glass
	Lumen	21000-23000LM
	Viewing Angle	110°
	Color Temperature	4000K/4500K/5000K/5700K
	CRI	>80
ELECTRICAL	Input Voltage	100-277VAC 50/60Hz
	PF	≥0.9
	THD	≤20%
	Driver	1-10V dimming
	Optional Accessory	Motion Sensor/Surge-Protective Device
MATERIALS	LED Type	SMD2835 (0.5W)
	LED QTY	480 PCS
	Housing	Aluminum Alloy
	Housing Color	Any colors
	Cover	Flat clear glass
	Waterproof Rating	WET(IP65)
OTHERS	Operating Temperature	-40°C TO 55°C
	Operating Humidity	10%-90% RH
	Storage Temperature	-40°C TO 80°C
	Storage Humidity	10%-95% RH
	Warranty Time	5 Years

LIGHT DISTRIBUTION TESTING PARAMETERS

Photometric Results

IES Classification: Type II
 Total Rated Lamp Lumens: 21781.5 lm
 Efficiency: 100%
 Upward Ratio: 1%
 Central Intensity: 7643.78 cd
 Pos of Max. Intensity: H337.5 V2

Longitudinal Classification: Very Short
 Measurement Flux: 21781.5 lm
 Downward Ratio: 99%
 Luminaire Efficacy Rating (LER): 144.55
 Max. Intensity: 7671.46 cd

Luminous Intensity Distribution Curve

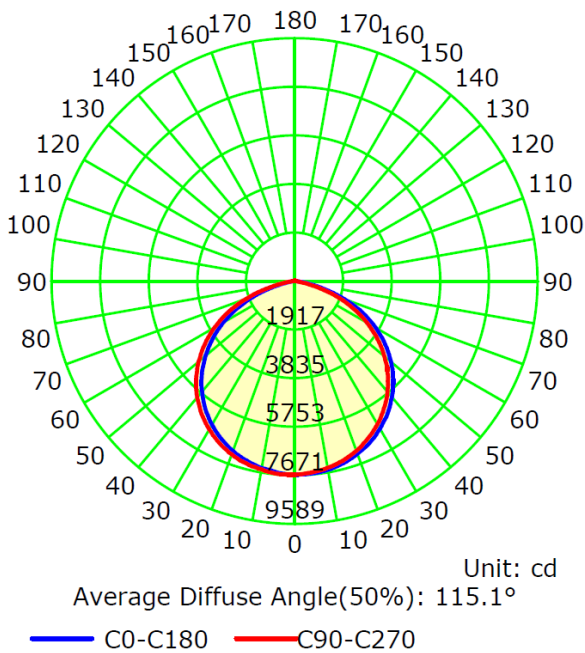

The Average Illuminance Effective Figure

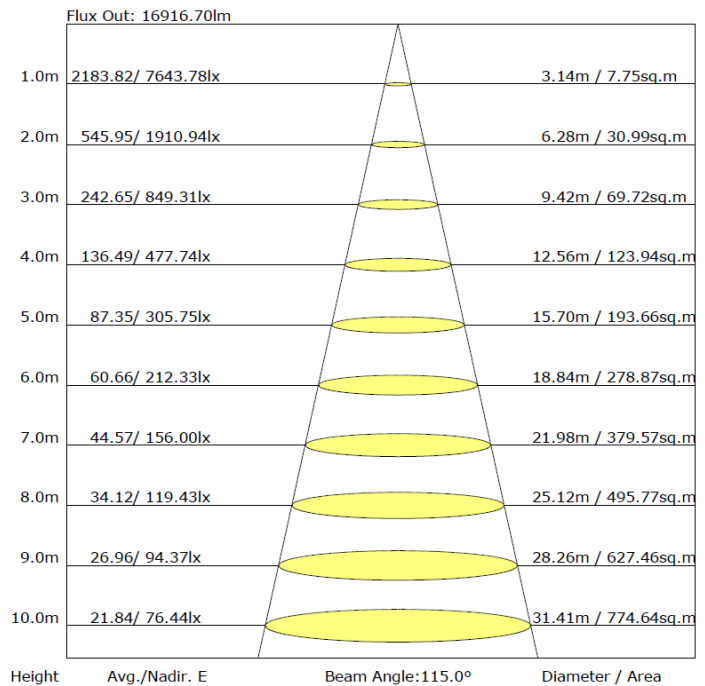

USER NOTICE

- Please turn off power before installing or changing assembly parts.
- The input voltage and lamp's should match. After connecting the power line, please make sure the wiring section is insulated.
- Non-professionals must not install and disassemble the lamps.

TROUBLESHOOTING

Trouble	Check points
Flickering light	Turn off the power and turn on again in 3 minutes. If same phenomena occurs, then call agencies.
Not working	Please check the connection.