



NAME: LED Flood Light

P/N: LF4506-30WXYA1-aaK

Note: aa in P/N represent CCT, can be 30, 40, 50

Advantage:

- UL cUL certificate
- Seoul Semiconductor Chip, high CRI
- Input voltage 100-277Vac
- No UV or IR in the beam
- Easy to install and operate
- Energy saving, Long lifespan
- Instant start, NO flickering, NO humming
- Green and eco-friendly without mercury.

Application:

- ◆ Factory floor, libraries, square, park;
- ◆ Supermarkets, railway stations;
- ◆ Advertising lighting, etc.

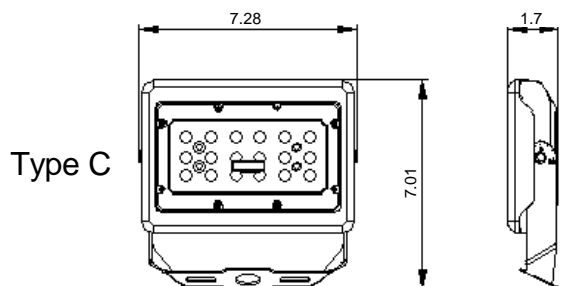
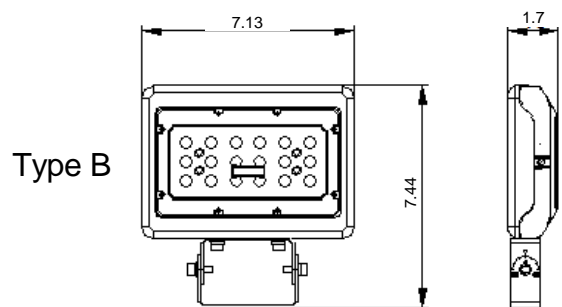
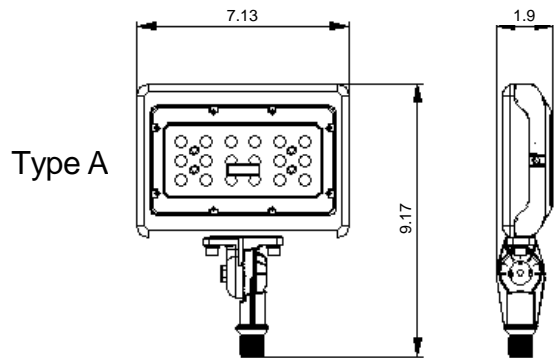

Product Specifications

Product name	LED Flood Light
Part No	LF4506-30WXYA1-aaK
Dimension	Type A: 233*181*49 mm
	Type B: 189*181*43mm
	Type C: 178*185*43 mm

Technical Characteristic

Color temperature	3000K/4000K/5000K
CRI	>80
Lumen	3450-3750 LM
Input Power	30W
Beam Angle(10%)	150°
Beam Angle(50%)	110°
Input Voltage	100-277Vac 50/60Hz
Optional	Surge Protection Device
PF	>0.9
Waterproof Rating	WET (IP65)

Materials

LED Brand	SEOUL SEMICONDUCTOR
LED Type	Acrich MJT- 3030
LED QTY	36PCS
Housing	Aluminum +PC+Steel
Housing color	Black、 Brown

Others

Operating Temperature	-20°C TO 45°C
Operating Humidity	20%-90% RH
Storage Temperature	-30°C TO 80°C
Storage Humidity	10%-95%
Application	Outdoor / Indoor
Safety Certification	UL、 cUL
Warranty Time	5 Years

Light Distribution Testing Parameters

DATA OF LAMP		PHOTOMETRIC DATA Eff: 114.98 lm/W			
MODEL	LF4506-30W	I _{max} (cd)	1317	S/MH(C0/180)	1.30
NOMINAL POWER (W)	30	LOR (%)	100.0	S/MH(C90/270)	1.29
RATED VOLTAGE (V)	120	TOTAL FLUX (lm)	3423.1	η UP, DN (C0-180)	0.0, 50.7
NOMINAL FLUX (lm)	3423.12	CIE CLASS	DIRECT	η UP, DN (C180-360)	0.0, 49.3
LAMPS INSIDE	1	η up (%)	0.0	CIBSE SHR NOM	1.25
TEST VOLTAGE (V)	120.0	η down (%)	100.0	CIBSE SHR MAX	1.35

Flux out: 2654 lm

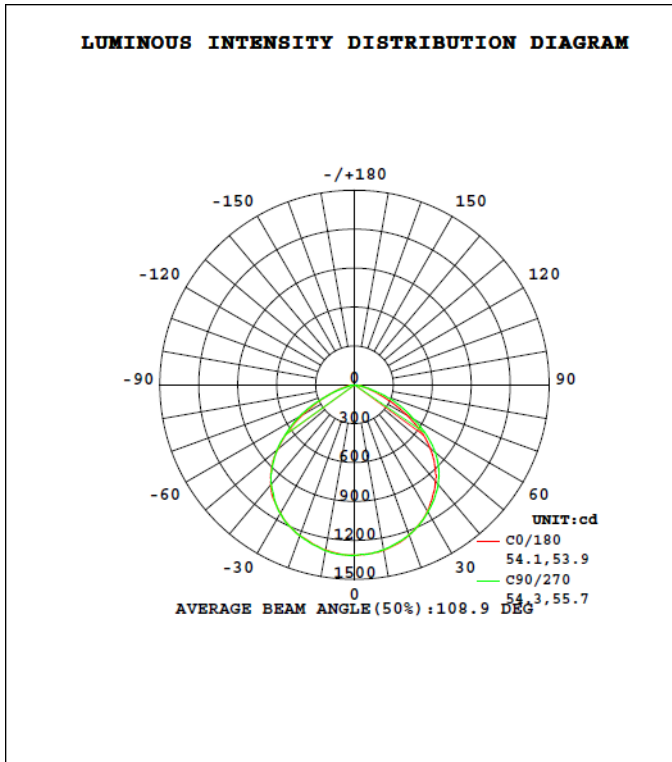

1m	445.9, 1318lx	274.22cm
2m	111.5, 329.4lx	548.44cm
3m	49.54, 146.4lx	822.66cm
4m	27.87, 82.36lx	1096.87cm
5m	17.84, 52.71lx	1371.09cm
6m	12.39, 36.61lx	1645.31cm
7m	9.100, 26.89lx	1919.53cm
8m	6.967, 20.59lx	2193.75cm
9m	5.505, 16.27lx	2467.97cm
10m	4.459, 13.18lx	2742.19cm

Height Eavg, Emax Angle: 107.79deg Diameter

Note: The Curves indicate the illuminated area and the average illumination when the luminaire is at different distance.

Package

		Type A	Type B	Type C
Lamps Net Weight		2.51 lbs	2.43 lbs	2.47 lbs.
Inner box	size	11.0*8.86*2.83in.		
	Qty/ Carton	1 PCS		
	Weight/ Carton	3.15 lbs	3.06 lbs.	3.11 lbs.
Outer box	size	18.3*11.6*12.4in.		
	Qty/ Carton	8 PCS		
	Weight/ Carton	26.9 lbs.	26.2 lbs.	26.7 lbs.

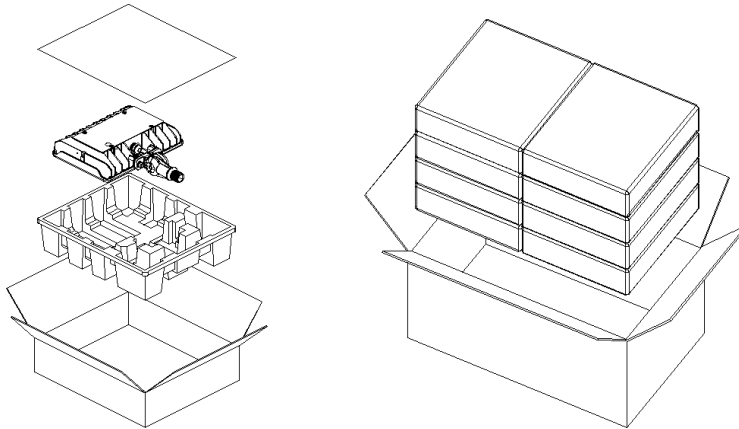

User Notice

- ◆ Please turn off power before installing or changing assembly parts.
- ◆ The input voltage and the lamp's should be matched. After connecting the power line, please make sure the wiring section is insulated.
- ◆ Non-professionals must not install or disassemble the lamps.

Troubleshooting

Troubles	Check points
Flickering	Turn off the power and turn on again in 3 minutes. If same phenomena occur, then call your dealer
Not working	Please check the connection